



# Index

**B2**  
  
**Ejector Pins-Nitrided-Parallel-Inch**

**B3**  
  
**Ejector Pins-Nitrided-Shoulder-Inch**

**B4**  
  
**Ejector Pins-Through Hard-Parallel-Inch**

**B5**  
  
**Ejector Pins-Through Hard-Shoulder-Inch**

**B6/B7**  
  
**Core Pins-Standard Hardness-(Soft)-Inch**  
**Core Pins-High Hardness-(Hard)-Inch**

**B8**  
  
**Core Pins-moldMAX-Inch**

**B9**  
  
**Ejector Sleeves-Nitrided-Parallel-Inch**

**B10**  
  
**Return Pins-Nitrided-Inch**

**B11**  
  
**Ejector Blades-Through Hard-Metric**

**B12**  
  
**Ejector Pins-Nitrided-Parallel-Metric**

**B13**  
  
**Ejector Pins-Nitrided-Shoulder-Metric**

**B14**  
  
**Ejector Pins-Through Hard-Parallel-Metric**

**B15**  
  
**Ejector Pins-Through Hard-Shoulder-Metric**

**B16**  
  
**Ejector Sleeves-Nitrided-Parallel-Metric**

**B17**  
  
**Ejector Sleeves-Through Hard-Parallel-Metric**

**B18**  
  
**D-Head Ejector Pins**

**B19**  
  
**Oversize Ejector Sleeves**

**B20/B21**  
  
**Core Pin Retainers/Knockout Rod Extensions**

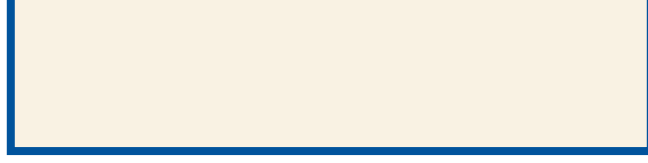
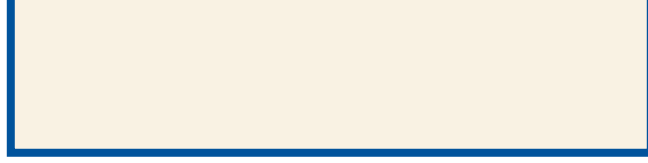



# Ejector Pins

## Nitrided - Parallel Inch

Material • AISI: H13  
• 1.2344

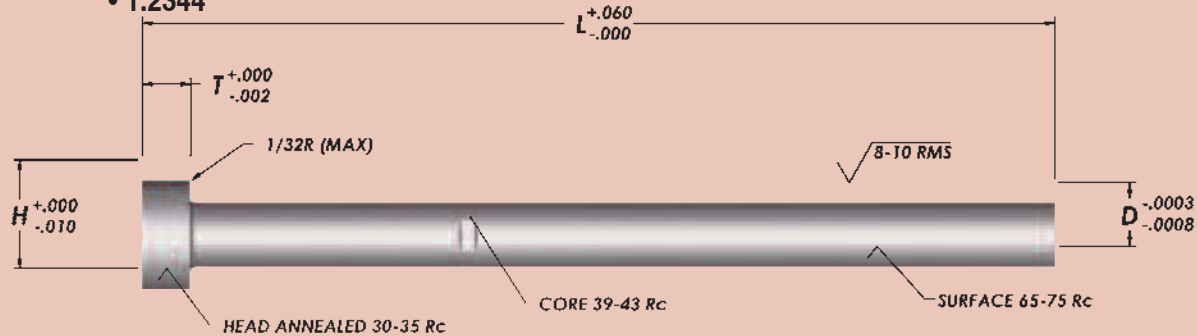

D	Cat. No.	L														H	T	
		6"		10"		14"		18"		25"		36"	39"	42"	45"			50"
		STD.	+005	STD.	+005	STD.	+005	STD.	+005	STD.	+005	STD.	STD.					
1/32	EP03	<b>L06P</b>	<b>L065</b>														1/4	1/8
3/64	EP04	L06P	<b>L065</b>														1/4	1/8
1/16	EP06	L06P		L10P	<b>L10P5</b>												1/4	1/8
5/64	EP07	L06P		L10P	<b>L10P5</b>												1/4	1/8
3/32	EP09	L06P		L10P	<b>L10P5</b>												1/4	1/8
7/64	EP10	L06P		L10P	<b>L10P5</b>												1/4	1/8
1/8	EP12	L06		L10	L105	L14	L145	L18		L25							1/4	1/8
9/64	EP14			L10		L14	<b>L145</b>										1/4	1/8
5/32	EP15	L06		L10	L105	L14	L145	L18		L25		<b>L36</b>					9/32	5/32
11/64	EP17			L10		L14	<b>L145</b>	L18									11/32	3/16
3/16	EP18	L06		L10	L105	L14	L145	L18		L25			L39		<b>L45</b>	<b>L50</b>	3/8	3/16
13/64	EP20			L10		L14	<b>L145</b>	L18		L25							3/8	3/16
7/32	EP21	L06		L10	L105	L14	<b>L145</b>	L18		L25							13/32	3/16
15/64	EP23			L10		L14	<b>L145</b>	L18		L25							13/32	3/16
1/4	EP25	L06		L10	L105	L14	L145	L18	L185	L25	<b>L255</b>	L36	L39				7/16	3/16
17/64	EP26			L10		L14	<b>L145</b>	L18		L25						<b>L50</b>	7/16	1/4
9/32	EP28	L06		L10	L105	L14	<b>L145</b>	L18		L25							7/16	1/4
19/64	EP29			L10		L14	<b>L145</b>	L18		L25							1/2	1/4
5/16	EP31	L06		L10	L105	L14	L145	L18	L185	L25	L255	L36	L39		<b>L50</b>		1/2	1/4
21/64	EP32			L10		L14	<b>L145</b>	L18		L25							9/16	1/4
11/32	EP34	L06		L10	L105	L14	<b>L145</b>	L18		L25							9/16	1/4
23/64	EP35			L10		L14	<b>L145</b>	L18		L25							5/8	1/4
3/8	EP37	L06		L10	L105	L14	L145	L18	L185	L25	L255	L36	L39		<b>L50</b>		5/8	1/4
25/64	EP39			<b>L10</b>		<b>L14</b>	<b>L145</b>										5/8	1/4
13/32	EP40	L06		L10	L105	L14	<b>L145</b>	L18		L25							11/16	1/4
27/64	EP42			<b>L10</b>		<b>L14</b>	<b>L145</b>										11/16	1/4
7/16	EP43	L06		L10	L105	L14	L145	L18		L25		L36	L39				11/16	1/4
29/64	EP45			<b>L10</b>		<b>L14</b>	<b>L145</b>										11/16	1/4
15/32	EP46	<b>L06</b>		L10	L105	L14	<b>L145</b>	L18		L25							3/4	1/4
31/64	EP48			<b>L10</b>		<b>L14</b>	<b>L145</b>										3/4	1/4
1/2	EP50	L06		L10	L105	L14	L145	L18	L185	L25	L255	L36	L39	<b>L42</b>	<b>L50</b>		3/4	1/4
17/32	EP53	<b>L06</b>		L10		L14	<b>L145</b>										3/4	1/4
9/16	EP56	L06		L10		L14		L18		L25			L39		<b>L50</b>		13/16	1/4
5/8	EP62	L06		L10		L14		L18		L25		L36	L39		<b>L50</b>		7/8	1/4
11/16	EP68	<b>L06</b>		L10		L14		L18		L25							15/16	1/4
3/4	EP75	L06		L10		L14		L18		L25		L36	L39		<b>L45</b>	<b>L50</b>		
7/8	EP87	<b>L06</b>		L10		L14		L18		L25			L39		<b>L50</b>		1-1/8	1/4
1	EP100	L06		L10		L14		L18		L25		L36	L39	<b>L42</b>	<b>L45</b>	<b>L50</b>		

- To order, add overall length "L" to Catalog Number. Example: EP04L06P
- Sizes marked in blue print are available but generally not stocked. Call for price and delivery. Example: EP06L10P
- New Items shown in bold print. Example: EP14L145



# Ejector Pins

## Nitrided - Shoulder Inch

Material • AISI: H13  
• 1.2344

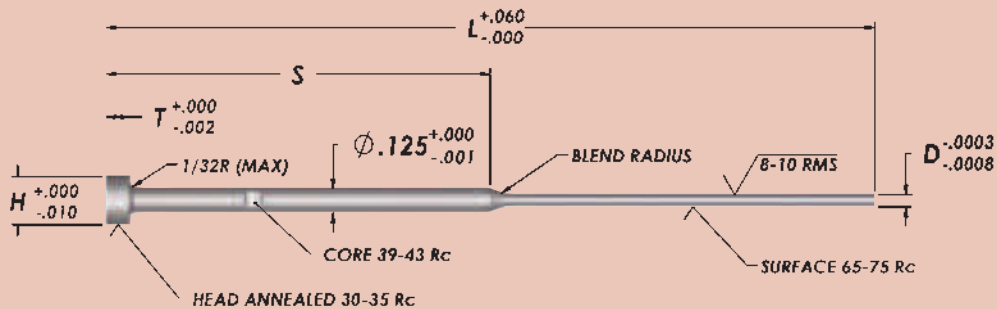

D	S	Cat. No.	L						H	T
			6"		10"		14"			
			STD.	+0.005	STD.	+0.005	STD.	+0.005		
1/32	1/2	EP03	L06-1/2	<b>L065-1/2</b>					1/4	1/8
	2	EP03	L06-2		<b>L10-2</b>	<b>L105-2</b>				
3/64	1/2	EP04	L06-1/2		L10-1/2	L105-1/2	L14-1/2		1/4	1/8
	2	EP04	L06-2		L10-2	L105-2	L14-2			
	3	EP04			L10-3					
	4	EP04			L10-4	<b>L105-4</b>	<b>L14-4</b>	<b>L145-4</b>		
1/16	1/2	EP06	L06-1/2		L10-1/2	L105-1/2	L14-1/2		1/4	1/8
	2	EP06	L06-2		L10-2	L105-2	L14-2			
	3	EP06			L10-3					
	4	EP06			L10-4	<b>L105-4</b>	<b>L14-4</b>	<b>L145-4</b>		
5/64	1/2	EP07	L06-1/2		L10-1/2	L105-1/2	L14-1/2		1/4	1/8
	2	EP07	L06-2		L10-2	L105-2	L14-2			
	3	EP07			L10-3					
	4	EP07			L10-4	<b>L105-4</b>	<b>L14-4</b>	<b>L145-4</b>		
3/32	1/2	EP09	L06-1/2		L10-1/2	L105-1/2	L14-1/2		1/4	1/8
	2	EP09	L06-2		L10-2	L105-2	L14-2			
	3	EP09			L10-3					
	4	EP09			L10-4	<b>L105-4</b>	<b>L14-4</b>	<b>L145-4</b>		
7/64	1/2	EP10	L06-1/2		L10-1/2	L105-1/2	L14-1/2		1/4	1/8
	2	EP10	L06-2		L10-2	L105-2	L14-2			
	3	EP10			L10-3					
	4	EP10			L10-4	<b>L105-4</b>	<b>L14-4</b>	<b>L145-4</b>		

- To order, add overall length "L" to Catalog Number. Example: EP03L06-1/2
- Sizes marked in blue print are available but generally not stocked. Call for price and delivery. Example: EP04L10-3
- New Items shown in bold print. Example: EP03**L065-1/2**



# Ejector Pins Through Hard - Parallel Inch

Material • AISI: H13  
• 1.2344

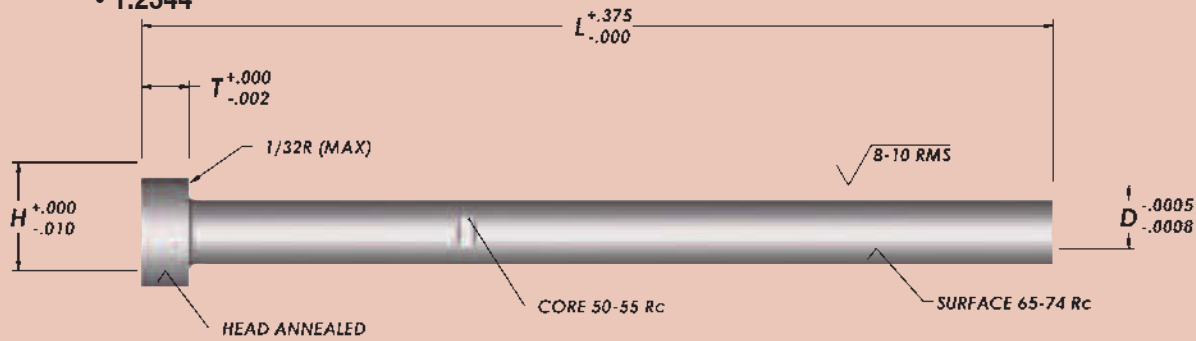

D	Cat. No.	L						H	T	
		6"		10"		14"				18"
		STD.	+0.005	STD.	+0.005	STD.	+0.005			
1/32	RHX-02	<b>L06</b>	<b>L065</b>					1/4	1/8	
3/64	RHX-03	L06	<b>L065</b>					1/4	1/8	
1/16	RHX-05	L06		L10	L105			1/4	1/8	
5/64	RHX-06	L06		L10	L105			1/4	1/8	
3/32	RHX-07	L06		L10	L105			1/4	1/8	
7/64	RHX-08	L06		L10	L105			1/4	1/8	
1/8	RHX-09	L06		L10	L105	L14	L145	1/4	1/8	
9/64	RHX-10	L06		L10	L105	L14	<b>L145</b>	1/4	1/8	
5/32	RHX-11	L06		L10	L105	L14	L145	9/32	5/32	
11/64	RHX-12	L06		L10	L105	L14	<b>L145</b>	11/32	3/16	
3/16	RHX-13	L06		L10	L105	L14	L145	3/8	3/16	
13/64	RHX-14	L06		L10		L14	<b>L145</b>	3/8	3/16	
7/32	RHX-15	L06		L10	L105	L14	<b>L145</b>	13/32	3/16	
15/64	RHX-16	L06		L10		L14	<b>L145</b>	13/32	3/16	
1/4	RHX-17	L06		L10	L105	L14	L145	<b>L18</b>	7/16	3/16
17/64	RHX-18	L06		L10		L14	<b>L145</b>	7/16	1/4	
9/32	RHX-19	L06		L10	L105	L14	<b>L145</b>	7/16	1/4	
19/64	RHX-20	L06		L10		L14	<b>L145</b>	1/2	1/4	
5/16	RHX-21	L06		L10	L105	L14	L145	<b>L18</b>	1/2	1/4
21/64	RHX-22	L06		L10		L14	<b>L145</b>	9/16	1/4	
11/32	RHX-23	L06		L10	L105	L14	<b>L145</b>	9/16	1/4	
23/64	RHX-24	L06		L10		L14	<b>L145</b>	5/8	1/4	
3/8	RHX-25	L06		L10	L105	L14	L145	<b>L18</b>	5/8	1/4
25/64	RHX-26	L06		L10		<b>L14</b>	<b>L145</b>	37/64	1/4	
13/32	RHX-27	L06		L10	L105	L14	<b>L145</b>	11/16	1/4	
27/64	RHX-28	L06		L10		<b>L14</b>	<b>L145</b>	11/16	1/4	
7/16	RHX-29	L06		L10	L105	L14	L145	11/16	1/4	
29/64	RHX-30	L06		L10		<b>L14</b>	<b>L145</b>	45/64	1/4	
15/32	RHX-31	L06		L10	L105	L14	<b>L145</b>	3/4	1/4	
31/64	RHX-32	L06		L10		<b>L14</b>	<b>L145</b>	3/4	1/4	
1/2	RHX-33	L06		L10	L105	L14	L145	<b>L18</b>	3/4	1/4
17/32	RHX-34	<b>L06</b>		<b>L10</b>		<b>L14</b>		3/4	1/4	
9/16	RHX-35	<b>L06</b>		<b>L10</b>		<b>L14</b>		13/16	1/4	
5/8	RHX-37	<b>L06</b>		<b>L10</b>		<b>L14</b>		<b>L18</b>	7/8	1/4
11/16	RHX-39	<b>L06</b>		<b>L10</b>		<b>L14</b>		15/16	1/4	
3/4	RHX-41	<b>L06</b>		<b>L10</b>		<b>L14</b>		<b>L18</b>	1	1/4
7/8	RHX-45	<b>L06</b>		<b>L10</b>		<b>L14</b>		1-1/8	1/4	
1	RHX-47	<b>L06</b>		<b>L10</b>		<b>L14</b>		1-1/4	1/4	

• To order, add overall length "L" to Catalog Number. Example: RHX-03L06



# Ejector Pins Through Hard - Shoulder Inch

Material • AISI: H13  
• 1.2344

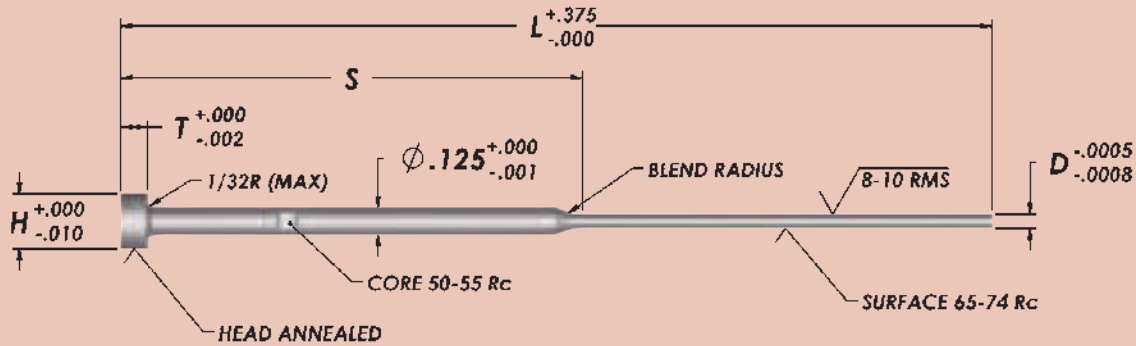

D	S	Cat. No.	L					H	T
			STD.	STD.	+0.005	STD.	+0.005		
1/32	1/2	RHX-02-1/2	L06					1/4	1/8
	2	RHX-02-2	L06						
	3	RHX-02-3		L10	L105				
	4	RHX-02-4		L10	L105				
3/64	1/2	RHX-03-1/2	L06					1/4	1/8
	2	RHX-03-2	L06	L10	L105				
	3	RHX-03-3		L10	L105				
	4	RHX-03-4		L10	L105				
1/16	1/2	RHX-05-1/2	L06	L10	L105			1/4	1/8
	2	RHX-05-2	L06	L10	L105	L14	L145		
	3	RHX-05-3		L10	L105				
	4	RHX-05-4		L10	L105				
5/64	1/2	RHX-06-1/2	L06	L10	L105			1/4	1/8
	2	RHX-06-2	L06	L10	L105	L14	L145		
	3	RHX-06-3		L10	L105				
	4	RHX-06-4		L10	L105				
3/32	1/2	RHX-07-1/2	L06	L10	L105			1/4	1/8
	2	RHX-07-2	L06	L10	L105	L14	L145		
	3	RHX-07-3		L10	L105				
	4	RHX-07-4		L10	L105				
7/64	1/2	RHX-08-1/2	L06	L10	L105			1/4	1/8
	2	RHX-08-2	L06	L10	L105	L14	L145		
	3	RHX-08-3		L10	L105				
	4	RHX-08-4		L10	L105				

• To order, add overall length "L" to Catalog Number. Example: RHX-02-1/2L06



# Core Pins

## Standard Hardness (Soft)

### Inch

Material • AISI: H13  
• 1.2344

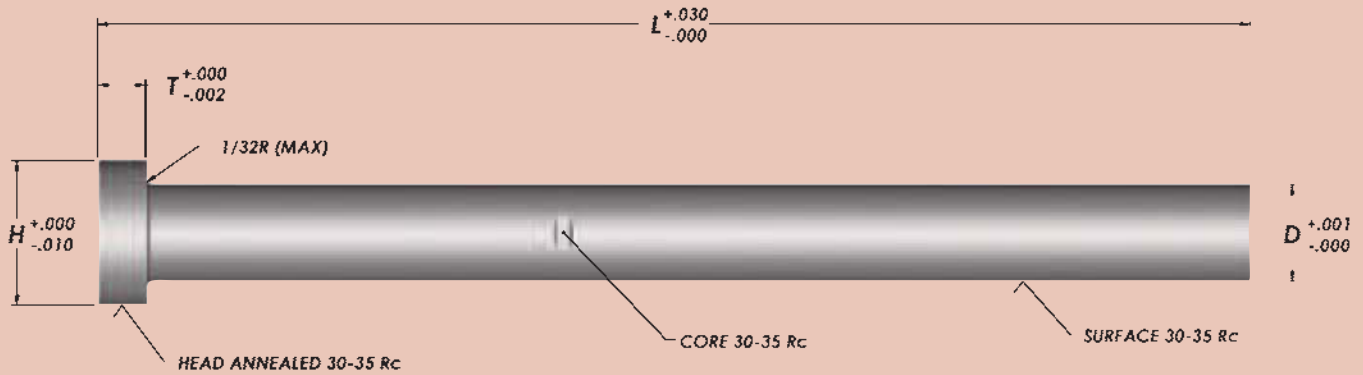

D	Cat. No.	L				H	T
		3"	6"	10"	14"		
3/32	CPS09	L03	L06	L10		1/4	1/8
7/64	CPS10	L03	L06	L10		1/4	1/8
1/8	CPS12	L03	L06	L10	L14	1/4	1/8
9/64	CPS14	L03	L06	L10	L14	1/4	1/8
5/32	CPS15	L03	L06	L10	L14	9/32	5/32
11/64	CPS17	L03	L06	L10	L14	11/32	3/16
3/16	CPS18	L03	L06	L10	L14	3/8	3/16
13/64	CPS20	L03	L06	L10	L14	3/8	3/16
7/32	CPS21	L03	L06	L10	L14	13/32	3/16
1/4	CPS25	L03	L06	L10	L14	7/16	3/16
9/32	CPS28	L03	L06	L10	L14	7/16	1/4
5/16	CPS31	L03	L06	L10	L14	1/2	1/4
11/32	CPS34	L03	L06	L10	L14	9/16	1/4
3/8	CPS37	L03	L06	L10	L14	5/8	1/4
13/32	CPS40	L03	L06	L10	L14	11/16	1/4
7/16	CPS43	L03	L06	L10	L14	11/16	1/4
15/32	CPS46	L03	L06	L10	L14	3/4	1/4
1/2	CPS50	L03	L06	L10	L14	3/4	1/4
9/16	CPS56		L06	L10	L14	13/16	1/4
5/8	CPS62		L06	L10	L14	7/8	1/4
3/4	CPS75		L06	L10	L14	1	1/4
7/8	CPS87		L06	L10	L14	1-1/8	1/4
1"	CPS100		L06	L10	L14	1-1/4	1/4

To order, add overall length L to Catalog Number. Example: CPH09L03



# Core Pins

## High Hardness (Hard)

### Inch

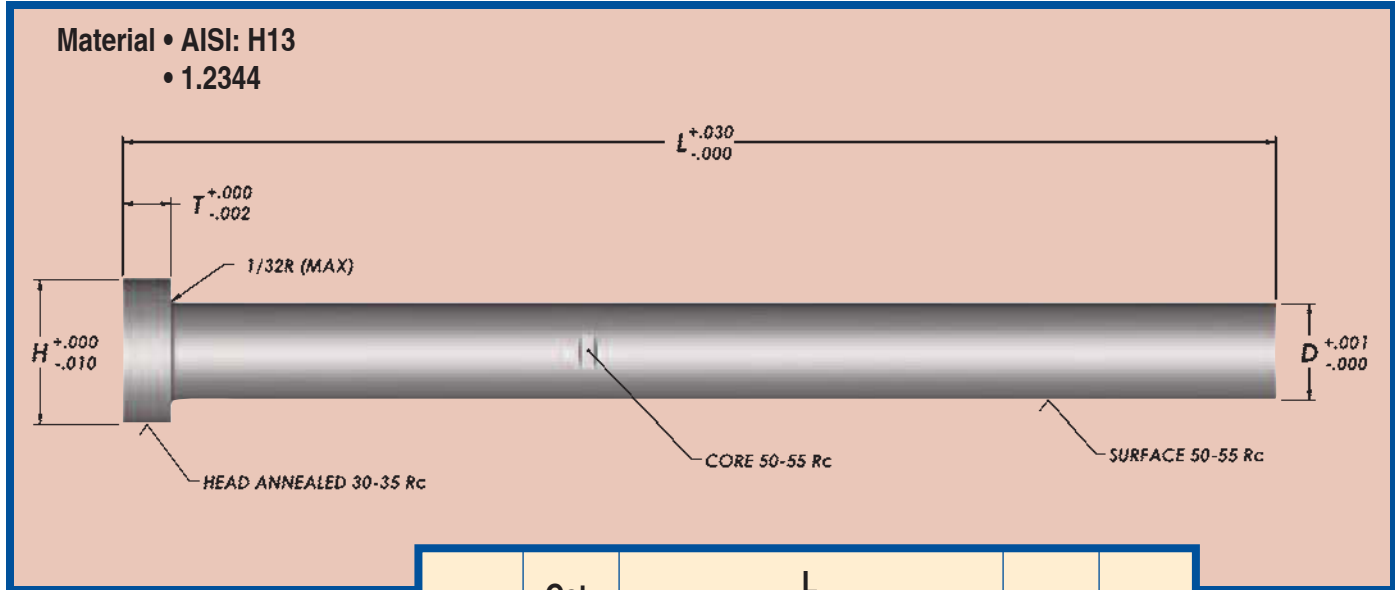

D	Cat. No.	L				H	T
		3"	6"	10"	14"		
3/32	CPH09	L03	L06	L10		1/4	1/8
7/64	CPH10	L03	L06	L10		1/4	1/8
1/8	CPH12	L03	L06	L10	L14	1/4	1/8
9/64	CPH14	L03	L06	L10	L14	1/4	1/8
5/32	CPH15	L03	L06	L10	L14	9/32	5/32
11/64	CPH17	L03	L06	L10	L14	11/32	3/16
3/16	CPH18	L03	L06	L10	L14	3/8	3/16
13/64	CPH20	L03	L06	L10	L14	3/8	3/16
7/32	CPH21	L03	L06	L10	L14	13/32	3/16
1/4	CPH25	L03	L06	L10	L14	7/16	3/16
9/32	CPH28	L03	L06	L10	L14	7/16	1/4
5/16	CPH31	L03	L06	L10	L14	1/2	1/4
11/32	CPH34	L03	L06	L10	L14	9/16	1/4
3/8	CPH37	L03	L06	L10	L14	5/8	1/4
13/32	CPH40	L03	L06	L10	L14	11/16	1/4
7/16	CPH43	L03	L06	L10	L14	11/16	1/4
15/32	CPH46	L03	L06	L10	L14	3/4	1/4
1/2	CPH50	L03	L06	L10	L14	3/4	1/4
9/16	CPH56		L06	L10	L14	13/16	1/4
5/8	CPH62		L06	L10	L14	7/8	1/4
3/4	CPH75		L06	L10	L14	1	1/4
7/8	CPH87		L06	L10	L14	1-1/8	1/4
1"	CPH100		L06	L10	L14	1-1/4	1/4

To order, add overall length L to Catalog Number. Example: CPH09L03



# Core Pins Copper Alloy Inch

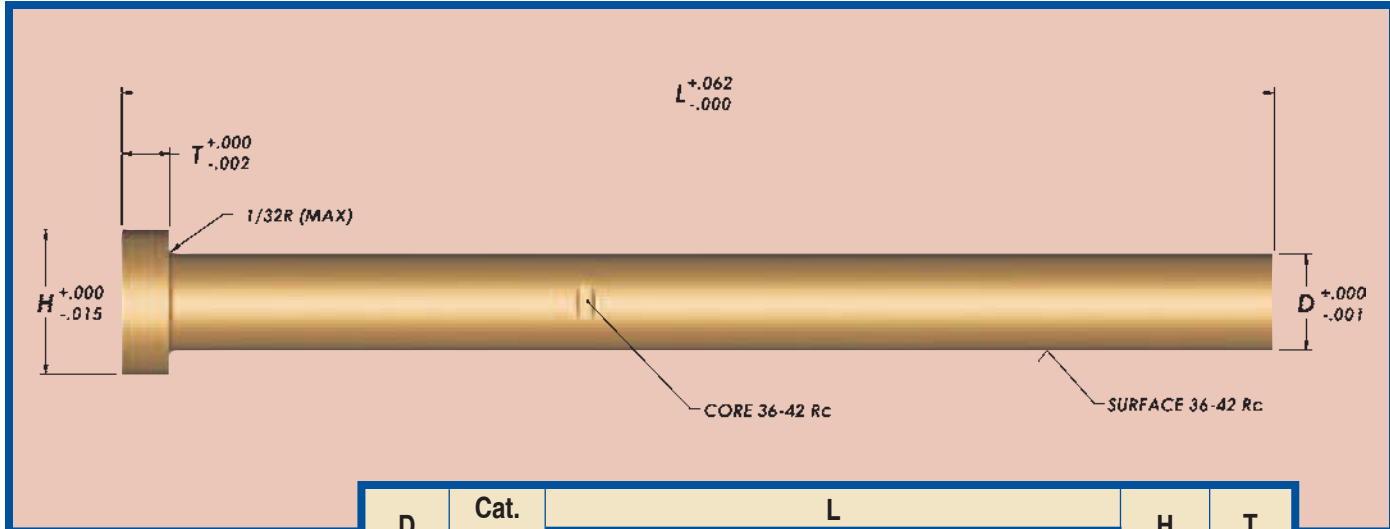

D	Cat. No.	L				H	T
		4"	8"	12"	18"		
1/8	MM12	L04	L08	L12		1/4	1/8
5/32	MM15	L04	L08	L12	L18	9/32	5/32
3/16	MM18	L04	L08	L12	L18	3/8	3/16
7/32	MM21	L04	L08	L12	L18	13/32	3/16
1/4	MM25	L04	L08	L12	L18	7/16	3/16
9/32	MM28	L04	L08	L12	L18	7/16	1/4
5/16	MM31	L04	L08	L12	L18	1/2	1/4
3/8	MM37	L04	L08	L12	L18	5/8	1/4
7/16	MM43	L04	L08	L12	L18	11/16	1/4
1/2	MM50	L04	L08	L12	L18	3/4	1/4
9/16	MM56	L04	L08	L12	L18	13/16	1/4
5/8	MM62	L04	L08	L12	L18	7/8	1/4
3/4	MM75	L04	L08	L12	L18	1	1/4

Copper Alloy Pins from DMS offer the highest combination of thermal conductivity and strength available. Made from prehardened copper alloy, our pins are 3 times stronger than competing copper alloy pins, and have thermal conductivity 3-5 times greater than steel pins.

The high strength provides longer life, resistance to abrasion and ease of machining.

The high thermal conductivity provides faster heat removal from critical areas, reducing molded part cost and post-mold shrinkage. The high-copper alloy provides excellent corrosion resistance and inherent lubricity and galling resistance.

Custom sizes are available.

- To order, add overall length "L" to Catalog Number. Example: MM12L04
- Material: Copper Alloy AB-4
- Specials available upon request.

### SAFE HANDLING

Copper Alloy in solid form poses no special health risk. Like many industrial materials, beryllium-containing materials may pose a health risk if recommended safe handling practices are not followed. Inhalation of airborne beryllium may cause a serious lung disorder in susceptible individuals. The Occupational Safety and Health Administration (OSHA) has set mandatory limits on occupational respiratory exposures.





# Ejector Sleeves

## Nitrided - Parallel Inch

Material • AISI: H13  
 • 1.2344  
 Nitrided • I.D. & O.D.

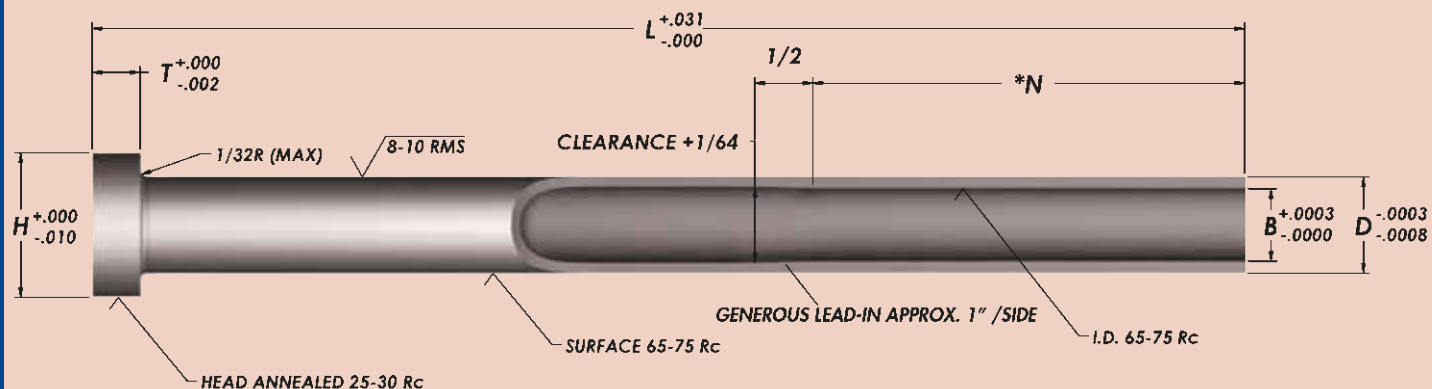

B I.D.	D O.D.	Cat. No.	L												H	T
			3"	4"	5"	6"	7"	8"	9"	10"	11"	12"	13"	14"		
3/32	3/16	SE02	L03	L04	L05	L06	L07	L08							3/8	3/16
1/8	7/32	SE03	L03	L04	L05	L06	L07	L08	L09	L10	L11	L12	L13	L14	13/32	3/16
5/32	1/4	SE04		L04	L05	L06	L07	L08	L09	L10	L11	L12	L13	L14	7/16	3/16
3/16	5/16	SE05		L04	L05	L06	L07	L08	L09	L10	L11	L12	L13	L14	1/2	1/4
7/32	11/32	SE55		L04	L05	L06	L07	L08	L09	L10	L11	L12	L13	L14	9/16	1/4
1/4	3/8	SE06		L04	L05	L06	L07	L08	L09	L10	L11	L12	L13	L14	5/8	1/4
5/16	7/16	SE07		L04	L05	L06	L07	L08	L09	L10	L11	L12	L13	L14	11/16	1/4
3/8	1/2	SE08		L04	L05	L06	L07	L08	L09	L10	L11	L12	L13	L14	3/4	1/4
7/16	5/8	SE09		L04	L05	L06	L07	L08	L09	L10	L11	L12	L13	L14	7/8	1/4
1/2	11/16	SE10		L04	L05	L06	L07	L08	L09	L10	L11	L12	L13	L14	15/16	1/4
9/16	3/4	SE11		L04	L05	L06	L07	L08	L09	L10	L11	L12	L13	L14	1	1/4
5/8	7/8	SE12		L04	L05	L06	L07	L08	L09	L10	L11	L12	L13	L14	1-1/8	1/4
3/4	1	SE13		L04	L05	L06	L07	L08	L09	L10	L11	L12	L13	L14	1-1/4	1/4

- To order, add overall length "L" to Catalog Number. Example: SE02L03
- Sizes marked in BLUE print are available, but generally not stocked. Call for price and delivery.  
 Example: SE02L08 \*(N) = 1-3/4 for SE02 and SE03 \*(N) = 2-1/4 for SE04 and larger.

### \* Extra Long Ejector Sleeves Inch Standard



N=2-3/8" for SE04  
 N=2-3/4" for SE05, SE055  
 N=3-1/4" for SE06 thru SE13

B I.D.	D O.D.	Cat. No.	L				H	T
			15"	16"	17"	18"		
5/32	1/4	SE04	L15	L16	L17	L18	7/16	3/16
3/16	5/16	SE05	L15	L16	L17	L18	1/2	1/4
7/32	11/32	SE55	L15	L16	L17	L18	9/16	1/4
1/4	3/8	SE06	L15	L16	L17	L18	5/8	1/4
5/16	7/16	SE07	L15	L16	L17	L18	11/16	1/4
3/8	1/2	SE08	L15	L16	L17	L18	3/4	1/4
7/16	5/8	SE09	L15	L16	L17	L18	7/8	1/4
1/2	11/16	SE10	L15	L16	L17	L18	15/16	1/4
9/16	3/4	SE11	L15	L16	L17	L18	1	1/4
5/8	7/8	SE12	L15	L16	L17	L18	1-1/8	1/4
3/4	1	SE13	L15	L16	L17	L18	1-1/4	1/4



# Return Pins Nitrided Inch

Material • AISI: H13  
• 1.2344

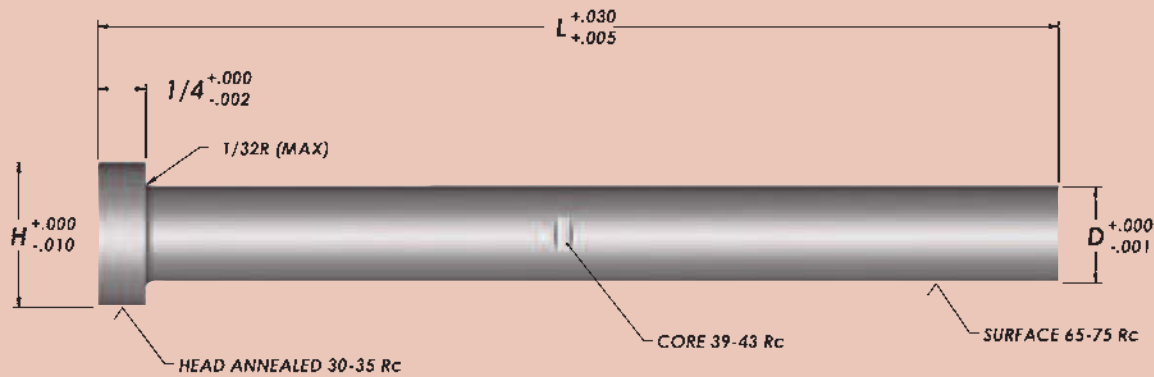

### D = 1/2"

L	3-9/16	4-1/16	4-9/16	5-1/16	5-9/16	6-1/16	6-9/16
H	3/4	3/4	3/4	3/4	3/4	3/4	3/4
Catalog Number	RP5356	RP5406	RP5456	RP5506	RP5556	RP5606	RP5656

### D = 5/8"

L	4-1/16	4-9/16	5-1/16	5-9/16	6-1/16	6-9/16	7-1/16	7-9/16	8-1/16
H	7/8	7/8	7/8	7/8	7/8	7/8	7/8	7/8	7/8
Catalog Number	RP6406	RP6456	RP6506	RP6556	RP6606	RP6656	RP6706	RP6756	RP6806

### D = 3/4"

L	4-15/16	5-7/16	5-15/16	6-7/16	6-15/16	7-7/16	7-15/16	8-7/16	8-15/16	9-7/16
H	1"	1"	1"	1"	1"	1"	1"	1"	1"	1"
Catalog Number	RP7493	RP7543	RP7593	RP7643	RP7693	RP7743	RP7793	RP7843	RP7893	RP7943





# Ejector Pins

## Nitrided - Parallel

### Metric

D	Cat. No.	L											H	T	R
		100	125	160	200	250	315	400	500	630	800	1000			
1.5	AN-01.5			160		250	315						3	1.5	0.2
1.6	AN-01.6			160	200								3	1.5	0.2
2.0	AN-02.0	100	125	160	200	250		400					4	2.0	0.2
2.2	AN-02.2			160		250		400					4	2.0	0.2
2.4	AN-02.4			160		250							5	2.0	0.3
2.5	AN-02.5	100	125	160	200	250	315						5	2.0	0.3
2.7	AN-02.7		125		200		315	400					5	2.0	0.3
2.9	AN-02.9			160		250							5	2.0	0.3
3.0	AN-03.0	100	125	160	200	250	315	400	500	630	800		6	3.0	0.3
3.1	AN-03.1			160		250							6	3.0	0.3
3.2	AN-03.2		125	160		250		400	500	630	800		6	3.0	0.3
3.4	AN-03.4			160		250							6	3.0	0.3
3.5	AN-03.5			160		250		400			800		7	3.0	0.3
3.7	AN-03.7			160		250		400	500	630			7	3.0	0.3
3.9	AN-03.9			160		250							7	3.0	0.3
4.0	AN-04.0	100	125	160	200	250	315	400	500	630	800		8	3.0	0.3
4.1	AN-04.1					250							8	3.0	0.3
4.2	AN-04.2			160	200	250	315	400	500	630	800		8	3.0	0.3
4.4	AN-04.4			160		250							8	3.0	0.3
4.5	AN-04.5			160		250		400	500	630	800	1000	8	3.0	0.3
4.9	AN-04.9			160		250							8	3.0	0.3
5.0	AN-05.0	100	125	160	200	250	315	400	500	630	800		10	3.0	0.3
5.1	AN-05.1					250							10	3.0	0.3
5.2	AN-05.2			160	200	250		400	500	630	800		10	3.0	0.3
5.4	AN-05.4			160		250							10	3.0	0.3
5.5	AN-05.5			160		250		400	500		800		10	3.0	0.3
5.7	AN-05.7			160		250							10	3.0	0.3
5.9	AN-05.9			160		250							10	3.0	0.3
6.0	AN-06.0	100	125	160	200	250	315	400	500	630	800	1000	12	5.0	0.5
6.1	AN-06.1					250							12	5.0	0.5
6.2	AN-06.2			160		250		400	500	630	800		12	5.0	0.5
6.5	AN-06.5			160		250		400	500				12	5.0	0.5
6.9	AN-06.9					250							12	5.0	0.5
7.0	AN-07.0			160		250	315	400	500	630	800	1000	12	5.0	0.5
7.2	AN-07.2			160		250							12	5.0	0.5
7.5	AN-07.5								500	630			12	5.0	0.5
7.8	AN-07.8					250							12	5.0	0.5
8.0	AN-08.0	100	125	160	200	250	315	400	500	630	800	1000	14	5.0	0.5
8.1	AN-08.1			160		250							14	5.0	0.5
8.2	AN-08.2			160		250		400	500	630	800	1000	14	5.0	0.5
8.4	AN-08.4			160		250							14	5.0	0.5
8.5	AN-08.5			160		250		400	500	630			14	5.0	0.5
9.0	AN-09.0			160		250		400	500	630			14	5.0	0.5
9.5	AN-09.5								500	630			14	5.0	0.5
9.7	AN-09.7			160		250							14	5.0	0.5
10.0	AN-10.0	100	125	160	200	250	315	400	500	630	800	1000	16	5.0	0.5
10.1	AN-10.1					250							16	5.0	0.5
10.2	AN-10.2			160		250		400	500	630	800		16	5.0	0.5
10.5	AN-10.5			160		250		400	500	630			16	5.0	0.5
11.0	AN-11.0			160		250		400	500	630			16	5.0	0.5
12.0	AN-12.0	100	125	160	200	250	315	400	500	630	800	1000	18	7.0	0.8
12.2	AN-12.2					250		400	500	630	800	1000	18	7.0	0.8
12.5	AN-12.5	100		160		250		400	500	630	800		18	7.0	0.8
14.0	AN-14.0			160	200	250	315	400	500		800	1000	22	7.0	0.8
14.2	AN-14.2					250							22	7.0	0.8
16.0	AN-16.0	100		160	200	250	315	400	500	630	800	1000	22	7.0	0.8
16.2	AN-16.2					250							22	7.0	0.8
18.0	AN-18.0			160	200	250	315	400	500	630	800	1000	24	8.0	1.0
20.0	AN-20.0		125	160	200	250	315	400	500	630	800	1000	26	7.0	0.8
25.0	AN-25.0			160	200	250	315	400	500	630	800	1000	32	10.0	1.0
32.0	AN-32.0				200	250	315	400	500	630	800	1000	40	10.0	1.0

• To order, add overall length "L" to Catalog Number. Example: AN-01,5L160



# Ejector Pins Nitrided - Parallel Metric

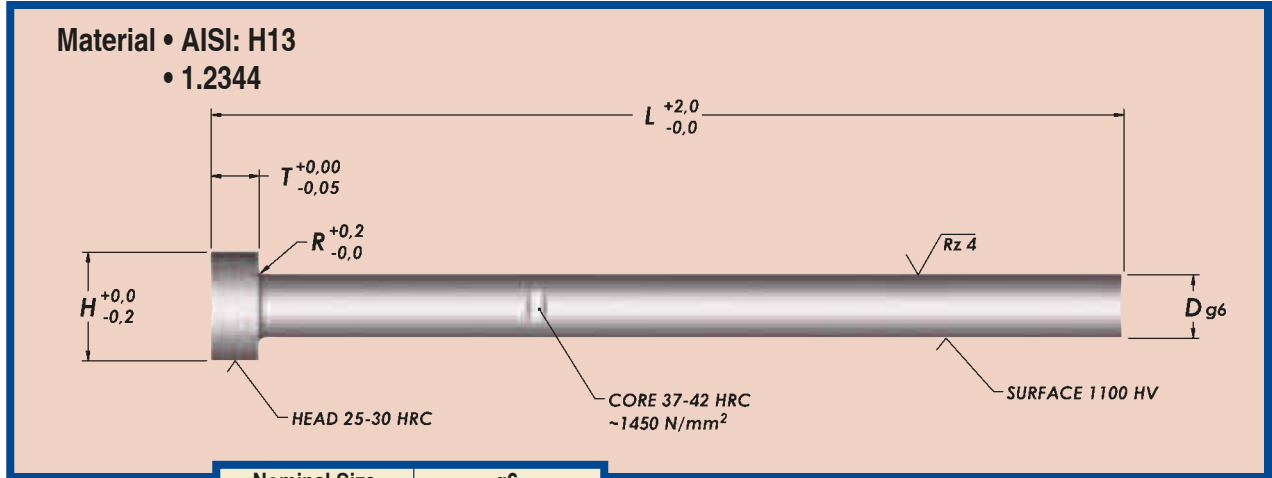

Nominal Size		g6	
Over	To	Tolerance (mm)	
0mm	3mm	-.002	-.008
3mm	6mm	-.004	-.012
6mm	10mm	-.005	-.014
10mm	18mm	-.006	-.017
18mm	30mm	-.007	-.020
30mm	50mm	-.009	-.025

# Ejector Pins Nitrided - Shoulder Metric

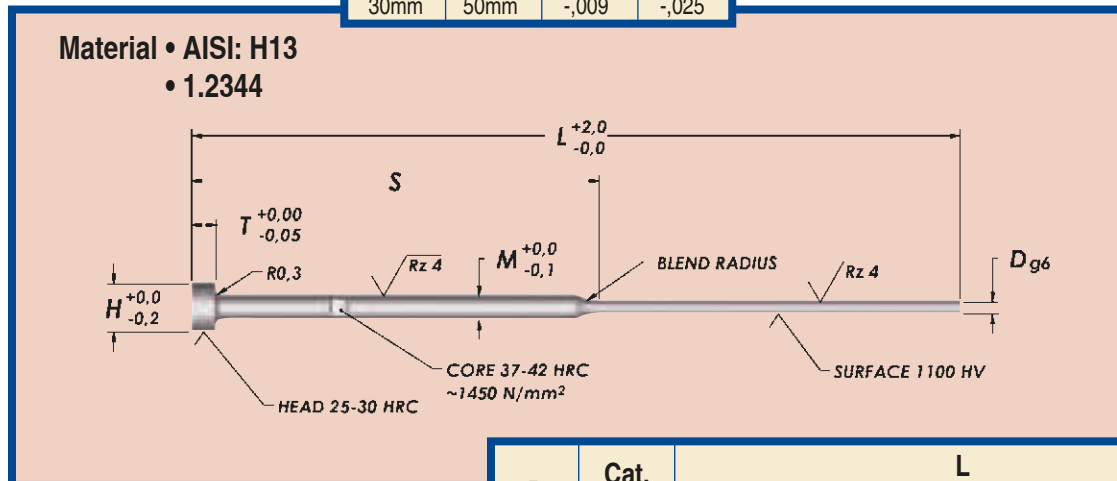

D	Cat. No.	L						M	H	T
		80 S=35	100 S=50	125 S=50	160 S=63	200 S=80	250 S=100			
0,8	CN-0,8			125				2	4	2
1,0	CN-1,0	080	100	125	160	200		2	4	2
1,1	CN-1,1			125				2	4	2
1,2	CN-1,2			125				2	4	2
1,3	CN-1,3			125				2	4	2
1,4	CN-1,4			125				2	4	2
1,5	CN-1,5	080	100	125	160	200	250	3	6	3
1,6	CN-1,6			125				3	6	3
1,7	CN-1,7	080			160			3	6	3
1,8	CN-1,8			125				3	6	3
2,0	CN-2,0	080	100	125	160	200	250	3	6	3
2,2	CN-2,2	080			160			3	6	3
2,5	CN-2,5		100	125	160	200	250	3	6	3
2,7	CN-2,7				160			3	6	3



# Ejector Pins Through Hard - Parallel Metric

Material • <math>\le 3\text{Ø}</math> : AISI L2 (1.2344)  
 • >3Ø : AISI ~01 (1.2516)

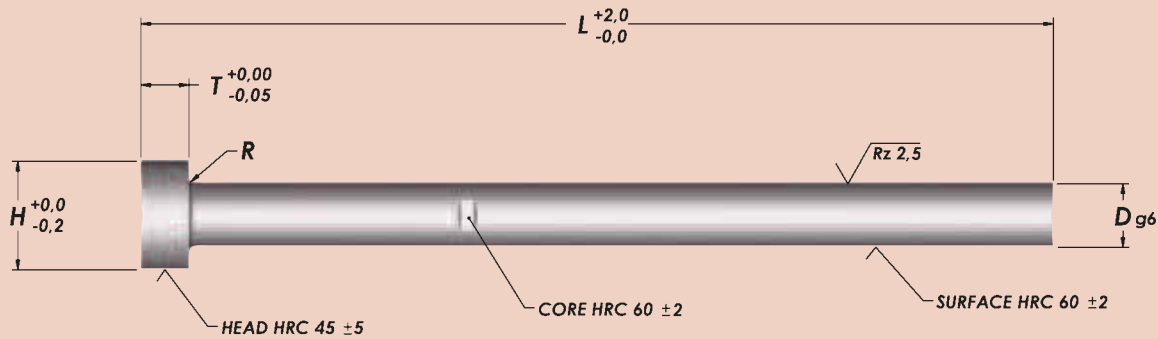

D	Cat. No.	L										H	T	R
		40	63	80	100	125	160	200	250	315	400			
1,5	AH-01,5				100	125	160	200	250			3	1,5	0,2
1,6	AH-01,6				100	125	160	200				3	1,5	0,2
2,0	AH-02,0	040	063	080	100	125	160	200	250			4	2,0	0,2
2,2	AH-02,2				100	125	160	200				4	2,0	0,2
2,5	AH-02,5				100	125	160	200	250			5	2,0	0,3
2,7	AH-02,7				100	125	160	200	250			5	2,0	0,3
3,0	AH-03,0	040	063	080	100	125	160	200	250	315	400	6	3,0	0,3
3,2	AH-03,2				100	125	160	200	250			6	3,0	0,3
3,5	AH-03,5				100	125	160	200	250	315	400	7	3,0	0,3
3,7	AH-03,7				100	125	160	200	250			7	3,0	0,3
4,0	AH-04,0	040	063	080	100	125	160	200	250	315	400	8	3,0	0,3
4,2	AH-04,2				100	125	160	200	250	315	400	8	3,0	0,3
4,5	AH-04,5				100	125	160	200	250			8	3,0	0,3
4,7	AH-04,7				100			200	250			8	3,0	0,3
5,0	AH-05,0	040	063	080	100	125	160	200	250	315	400	10	3,0	0,3
5,2	AH-05,2				100	125	160	200	250	315	400	10	3,0	0,3
5,5	AH-05,5				100	125	160	200	250	315		10	3,0	0,3
6,0	AH-06,0	040	063	080	100	125	160	200	250	315	400	12	5,0	0,5
6,2	AH-06,2				100	125	160	200	250	315	400	12	5,0	0,5
6,5	AH-06,5				100	125	160	200	250	315		12	5,0	0,5
7,0	AH-07,0				100	125	160	200	250	315	400	12	5,0	0,5
8,0	AH-06,0		063	080	100	125	160	200	250	315	400	14	5,0	0,5
8,2	AH-08,2			080	100	125	160	200	250	315	400	14	5,0	0,5
8,5	AH-08,5				100	125	160	200	250	315		14	5,0	0,5
9,0	AH-09,0				100	125	160	200	250	315		14	5,0	0,5
10,0	AH-10,0			080	100	125	160	200	250	315	400	16	5,0	0,5
10,2	AH-10,2					125	160	200	250	315	400	16	5,0	0,5
10,5	AH-10,5				100	125		200		315	400	16	5,0	0,5
11,0	AH-11,0						160	200	250	315		16	5,0	0,5
12,0	AH-12,0			080	100	125	160	200	250	315	400	18	7,0	0,8
12,2	AH-12,2						160	200	250	315		18	7,0	0,8
12,5	AH-12,5						160	200	250			18	7,0	0,8
14,0	AH-14,0				100	125	160	200	250	315	400	22	7,0	0,8
16,0	AH-16,0				100	125	160	200	250	315	400	22	7,0	0,8
18,0	AH-18,0						160	200	250	315	400	24	7,0	0,8
20,0	AH-20,0						160	200	250	315	400	26	8,0	1,0

• To order, add overall length "L" to Catalog Number. Example: AH-01,5L100



# Ejector Pins Through Hard - Shoulder Metric

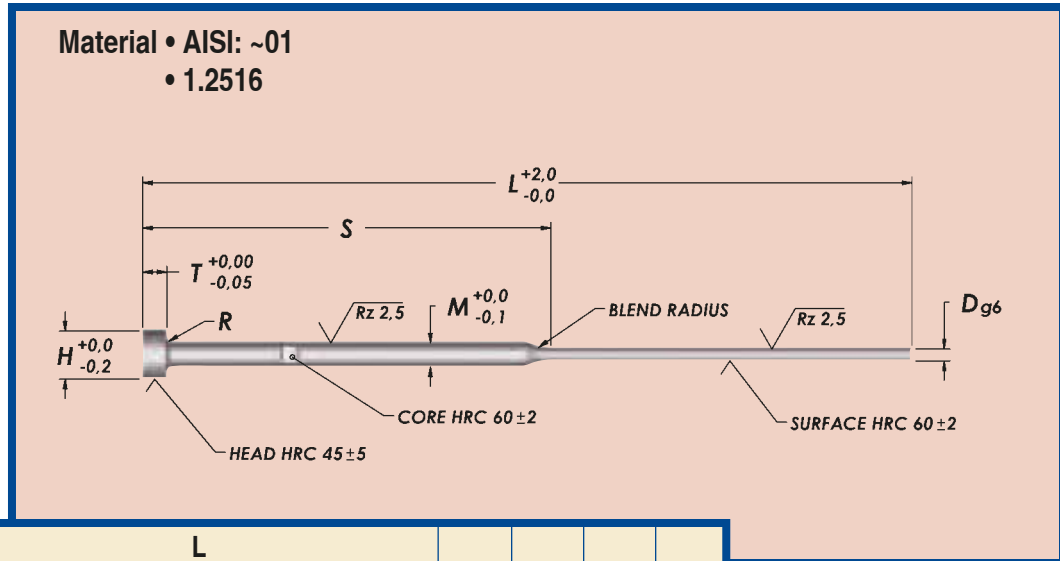

D	Cat. No.	L					M	H	T	R
		80 S=35	100 S=50	125 S=50	160 S=63	200 S=80				
0,8	CH-0,8	080	100	125	160	200	2	4	2	0,2
0,9	CH-0,9		100	125	160	200	2	4	2	0,2
1,0	CH-1,0	080	100	125	160	200	2	4	2	0,2
1,1	CH-1,1		100	125	160	200	2	4	2	0,2
1,2	CH-1,2	080	100	125	160	200	2	4	2	0,2
1,3	CH-1,3	080	100	125	160	200	2	4	2	0,2
1,4	CH-1,4		100	125	160	200	2	4	2	0,2
1,5	CH-1,5	080	100	125	160	200	3	6	3	0,3
1,6	CH-1,6		100	125	160	200	3	6	3	0,3
1,7	CH-1,7		100	125	160	200	3	6	3	0,3
1,8	CH-1,8		100	125	160	200	3	6	3	0,3
1,9	CH-1,9		100	125	160	200	3	6	3	0,3
2,0	CH-2,0		100	125	160	200	3	6	3	0,3
2,1	CH-2,1		100	125	160	200	3	6	3	0,3
2,2	CH-2,2		100	125	160	200	3	6	3	0,3
2,3	CH-2,3		100	125	160	200	3	6	3	0,3
2,4	CH-2,4		100	125	160	200	3	6	3	0,3
2,5	CH-2,5		100	125	160	200	3	6	3	0,3

• To order, add overall length "L" to Catalog Number. Example: CH-0,8L080

Nominal Size		g6	
Over	To	Tolerance (mm)	
0mm	3mm	-,002	-,008
3mm	6mm	-,004	-,012
6mm	10mm	-,005	-,014
10mm	18mm	-,006	-,017
18mm	30mm	-,007	-,020



# Ejector Sleeves

## Nitrided - Parallel Metric

Material • AISI: H13  
 • 1.2344  
 Nitrided • I.D. & O.D.

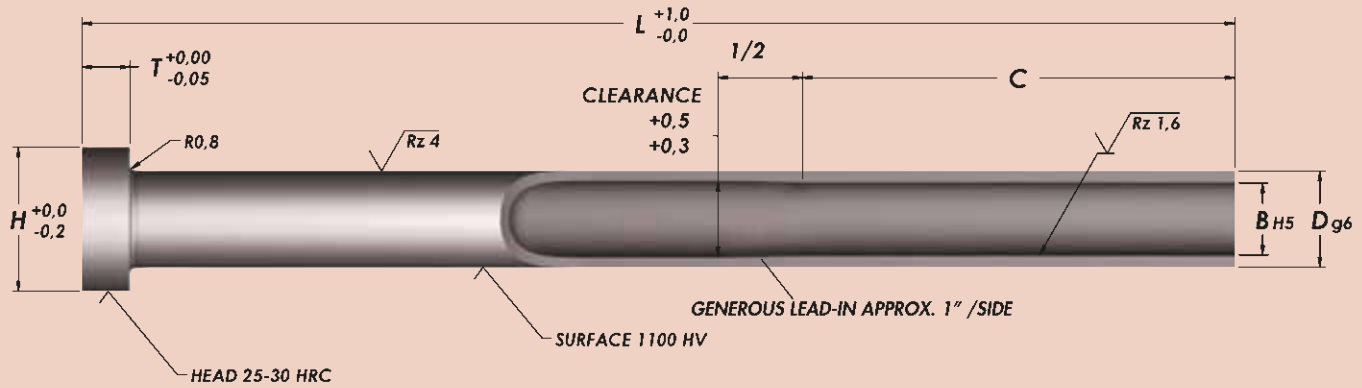

D O.D.	B I.D.	Catalog Number	L													C	H	T
			75	100	125	150	175	200	225	250	275	300	325	350	400			
4,0	2,0	SN-04,0x02,0	075	100	125	150	175	200								35	8,0	3,0
	2,2	SN-04,0x02,2	075	100	125	150												
5,0	2,5	SN-05,0x02,5	075	100	125	150										35	10,0	3,0
	2,7	SN-05,0x02,7	075	100	125	150												
	3,0	SN-05,0x03,0	075	100	125	150	175			250						45	10,0	3,0
6,0	3,2	SN-05,0x03,2	075	100	125	150	175	200										
	3,0	SN-06,0x03,0	075	100	125											45	12,0	5,0
	3,5	SN-06,0x03,5	075	100	125	150	175											
	3,7	SN-06,0x03,7	075	100	125	150												
	4,0	SN-06,0x04,0	075	100	125	150	175	200	225	250	275	300		400		50	12,0	5,0
8,0	4,2	SN-06,0x04,2	075	100	125	150	175		250									
	4,0	SN-08,0x04,0	075	100	125	150										50	14,0	5,0
	4,2	SN-08,0x04,2	075	100	125	150	175	200										
	5,0	SN-08,0x05,0	075	100	125	150	175	200	225	250		325						
10,0	6,0	SN-10,0x06,0	075	100	125	150	175	200	225	250	275					50	16,0	5,0
	6,2	SN-10,0x06,2	075	100	125	150	175	200	225									
12,0	8,0	SN-12,0x08,0	075	100	125	150	175	200	225	250			350			50	20,0	7,0
	8,2	SN-12,0x08,2	075	100	125	150	175	200	225	250								
14,0	10,0	SN-14,0x10,0		100	125	150	175	200	225	250						50	22,0	7,0
	10,2	SN-14,0x10,2		100	125	150	175	200		250								
16,0	12,0	SN-16,0x12,0		100	125	150	175	200	225	250						50	22,0	7,0

• To order, add overall length "L" to Catalog Number. Example: SN-04,0x02,0L075

Nominal Size		g6		H5	
Over	To	Tolerance (mm)		Tolerance (mm)	
0mm	3mm	-0,02	-0,08	+0,04	0
3mm	6mm	-0,04	-0,12	+0,05	0
6mm	10mm	-0,05	-0,14	+0,06	0
10mm	18mm	-0,06	-0,17	+0,08	0





# Ejector Sleeves Through Hard - Parallel Metric

Material • AISI 01  
• 1.2516

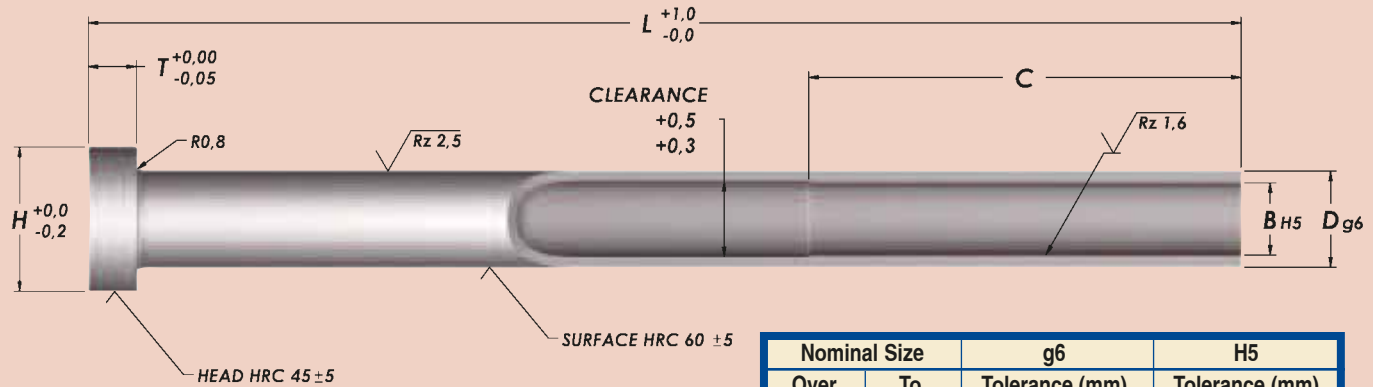

Nominal Size		g6		H5	
Over	To	Tolerance (mm)		Tolerance (mm)	
0mm	3mm	-.002	-.008	+.004	0
3mm	6mm	-.004	-.012	+.005	0
6mm	10mm	-.005	-.014	+.006	0
10mm	18mm	-.006	-.017	+.008	0
18mm	30mm	-.007	-.020	+.009	0

D O.D.	B I.D.	Catalog Number	L								H	T	C		
			75	100	125	150	175	200	225	250				275	
3,0	1,5	SH-03,0x01,5	075	100	125	150	175					35	6,0	3,0	
	1,6	SH-03,0x01,6	075	100	125	150	175								
4,0	2,0	SH-04,0x02,0	075	100	125	150	175	200	225			35	8,0	3,0	
	2,2	SH-04,0x02,2	075	100	125	150	175	200	225						
	2,5	SH-04,0x02,5	075	100	125	150	175	200	225						
5,0	2,5	SH-05,0x02,5	075	100	125	150	175	200	225	250		35	10,0	3,0	
	2,7	SH-05,0x02,7	075	100	125	150	175	200	225	250					
	3,0	SH-05,0x03,0	075	100	125	150	175	200	225	250	275				45
	3,2	SH-05,0x03,2	075	100	125	150	175	200	225	250	275				
6,0	3,0	SH-06,0x03,0	075	100	125	150	175	200	225	250	275	45	12,0	5,0	
	3,5	SH-06,0x03,5	075	100	125	150	175	200	225	250	275				
	4,0	SH-06,0x04,0	075	100	125	150	175	200	225	250	275				
	4,5	SH-06,0x04,5	075	100	125	150	175	200	225	250	275				
8,0	4,2	SH-08,0x04,2	075	100	125	150	175	200	225	250	275	45	14,0	5,0	
	5,0	SH-08,0x05,0	075	100	125	150	175	200	225	250	275				
	5,2	SH-08,0x05,2	075	100	125	150	175	200	225	250	275				
10,0	6,0	SH-10,0x06,0	075	100	125	150	175	200	225	250	275	45	16,0	5,0	
	6,2	SH-10,0x06,2	075	100	125	150	175	200	225	250	275				
12,0	8,0	SH-12,0x08,0	075	100	125	150	175	200	225	250	275	45	20,0	7,0	
	8,2	SH-12,0x08,2	075	100	125	150	175	200	225	250	275				
14,0	10,0	SH-14,0x10,0	075	100	125	150	175	200	225	250	275	45	22,0	7,0	
16,0	12,0	SH-16,0x12,0	075	100	125	150	175	200	225	250	275	45	22,0	7,0	
20,0	14,0	SH-20,0x14,0		100		150		200		250		45	26,0	8,0	

- To order, add overall length "L" to Catalog Number. Example: SH-03,0x02,0L075
- Sizes marked in blue print are available but generally not stocked.
- Call for price and delivery. Example: SH-03,0x01,5L075



# D-Head Ejector Pins

## Nitrided - Parallel

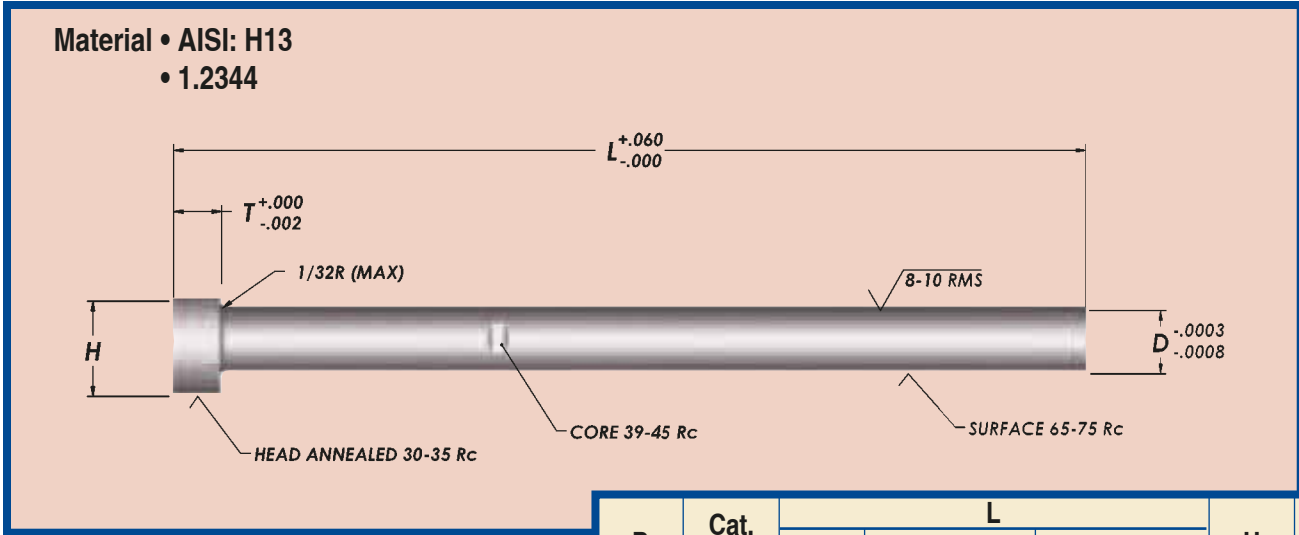

- No machining required.
- Save time – let us key your pins.

D	Cat. No.	L					H	T
		6"	10"	14"	18"	25"		
		STD.	STD.	STD.	STD.	STD.		
1/8	DPIN12	L06	L10	L14			1/4	1/8
9/64	DPIN14		L10	L14			1/4	1/8
5/32	DPIN15	L06	L10	L14	L18	L25	9/32	5/32
3/16	DPIN18	L06	L10	L14	L18	L25	3/8	3/16
7/32	DPIN21			L14			13/32	3/16
1/4	DPIN25	L06	L10	L14	L18	L25	7/16	3/16
5/16	DPIN31	L06	L10	L14	L18	L25	1/2	1/4
3/8	DPIN37	L06	L10	L14	L18	L25	5/8	1/4
1/2	DPIN50	L06	L10	L14	L18	L25	3/4	1/4
5/8	DPIN62	L06	L10	L14	L18	L25	7/8	1/4
3/4	DPIN75	L06	L10	L14	L18	L25	1	1/4
1	DPIN100	L06	L10	L14	L18	L25	1-1/4	1/4

- To order, add overall length "L" to Catalog Number. Example: DPIN12L06
- Other key headed pins not shown are available upon request. Check with our order desk.

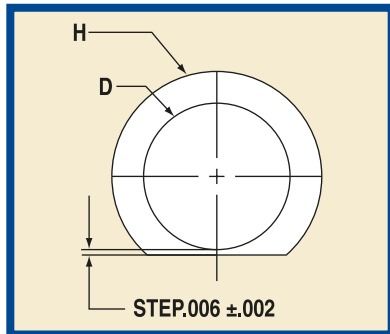

1/8 - 5/16 dia.

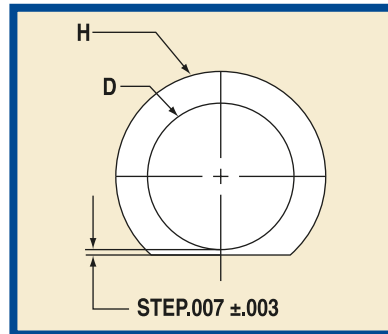

3/8 - 1" dia.



# Ejector Sleeves +.005 Oversize Nitrided - Parallel Inch

Material • AISI: H13  
• 1.2344  
Nitrided • I.D. & O.D.

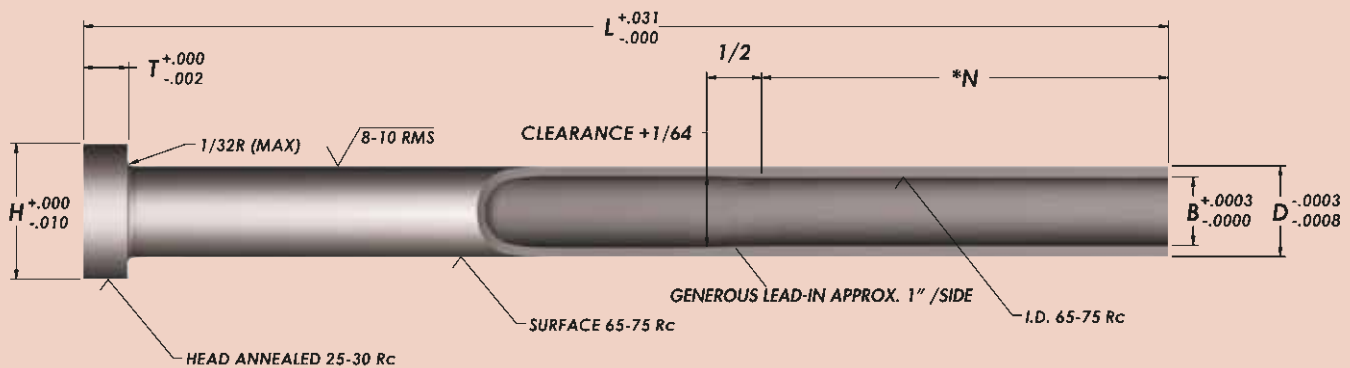

B I.D.	D O.D.	Cat. No.	L									H	T
			4"	5"	6"	7"	8"	9"	10"	11"	12"		
3/32	.1925	OSE02	L04	L05	L06	L07	L08	L09	L10	L11	L12	3/8	3/16
1/8	.2238	OSE03	L04	L05	L06	L07	L08	L09	L10	L11	L12	13/32	3/16
5/32	.2550	OSE04	L04	L05	L06	L07	L08	L09	L10	L11	L12	7/16	3/16
3/16	.3175	OSE05	L04	L05	L06	L07	L08	L09	L10	L11	L12	1/2	1/4
1/4	.3800	OSE06	L04	L05	L06	L07	L08	L09	L10	L11	L12	5/8	1/4
5/16	.4425	OSE07	L04	L05	L06	L07	L08	L09	L10	L11	L12	11/16	1/4
3/8	.5050	OSE08	L04	L05	L06	L07	L08	L09	L10	L11	L12	3/4	1/4

- To order, add overall length "L" to Catalog Number. Example: OSE02L04
  - Sizes marked in light print are available but generally not stocked. Call for price and delivery. Example: OSE02L11
  - \* (N) = 1-3/4 for OSE02 and OSE03
  - \* (N) = 2-1/4 for OSE04 and larger
- Any of DMS standard sleeves (from page B9) can be ordered oversize. Call our order desk for details.



# Core Pin Retainers



Catalog Number	D O.D. -.000 -.010	T Thread	Head Thickness -.002	L Length +.002 -.000	Hex Size	Recommended Pin Sizes
CPR56	.56	3/8 - 24	.125	.437	3/16	3/32 thru 5/32 diameters
CPR68	.68	1/2 - 20	.125	.437	1/4	11/64 thru 9/32 diameters
CPR93	.93	3/4 - 16	.125	.437	3/8	5/16 thru 7/16 diameters
CPR106	1.06	7/8 - 14	.125	.437	3/8	15/32 thru 9/16 diameters
CPR131	1.31	1-1/8 - 12	.125	.437	3/8	5/8 thru 3/4 diameters

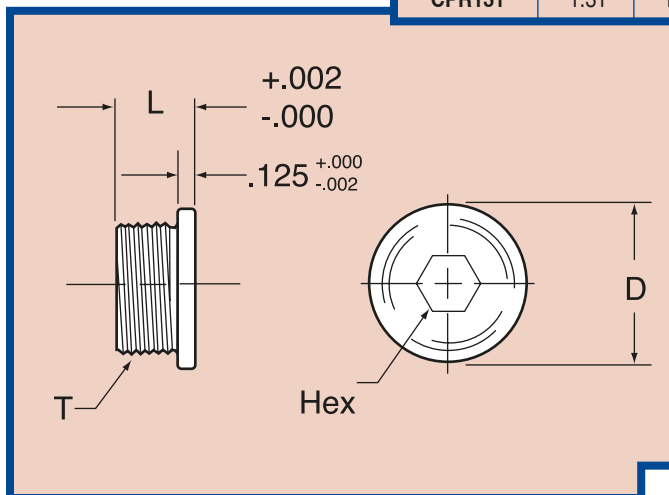

Material : 12L14: Black oxidized

- Allows for improved and more consistent installation and removal of core pins by toolmaker
- Does not force the head of the core pin head against the bottom of the counterbore

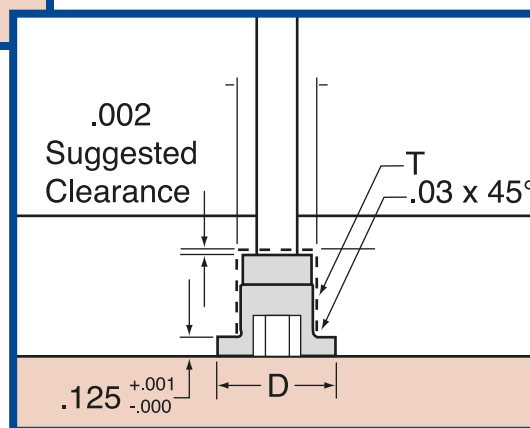



# Knockout Rod Extensions



## Hex Style

Catalog Number	T	L Length	Thread internal & external
KRE37-10	1.052	1.672	3/8 - 16
KRE37-15	1.552	2.172	3/8 - 16
KRE50-10	1.052	1.672	1/2 - 13
KRE50-15	1.552	2.175	1/2 - 13
KRE62-10	1.052	1.922	5/8 - 11
KRE62-15	1.552	2.422	5/8 - 11
KRE75-10	1.052	1.672	3/4 - 10
KRE75-15	1.552	2.422	3/4 - 10
KRE75-10NT*	1.052	1.922	3/4 - 10
KRE75-15NT*	1.552	2.422	3/4 - 10

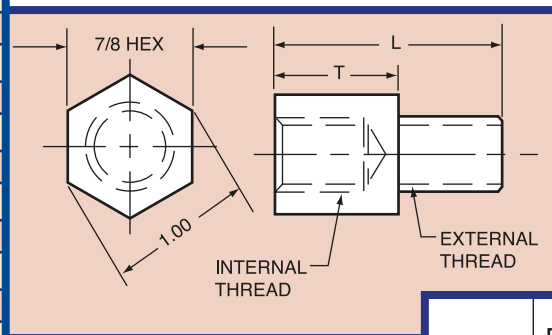

\*Note: External thread only. Tool maker to machine internal thread on "NT" style.

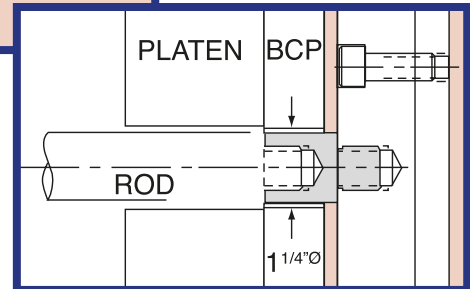

"L" DIMENSIONS:

1.052 = .875 (BCP) + .187 (Stop Pins) - .010  
 1.552 = 1.375 (BCP) + .187 (Stop Pins) - .010

## Round Style



Catalog Number	D	Thread
KR37-10	1.052	3/8 - 16
KR37-15	1.552	3/8 - 16
KR50-10	1.052	1/2 - 13
KR50-15	1.552	1/2 - 13
KR62-10	1.052	5/8 - 11
KR62-15	1.552	5/8 - 11
KR75-10	1.052	3/4 - 10
KR75-15	1.552	3/4 - 10
KR75-10NT*	1.052	no thread
KR75-15NT*	1.552	no thread

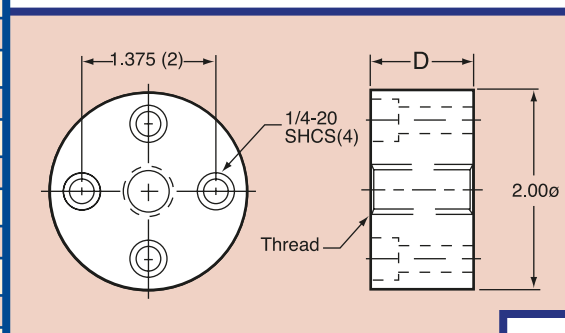

\*Note: No female thread. Tool maker to machine internal thread on "NT" style.

